



Standard Specification for Copper and Copper-Alloy Seamless Condenser and Heat Exchanger Tubes With Integral Fins¹

This standard is issued under the fixed designation B 359; the number immediately following the designation indicates the year of original adoption or, in the case of revision, the year of last revision. A number in parentheses indicates the year of last reapproval. A superscript epsilon (ϵ) indicates an editorial change since the last revision or reapproval.

This standard has been approved for use by agencies of the Department of Defense. Consult the DOD Index of Specifications and Standards for the specific year of issue which has been adopted by the Department of Defense.

1. Scope

1.1 This specification² describes seamless copper and copper alloy tubing on which the external or internal surface, or both, has been modified by a cold-forming process to produce an integral enhanced surface for improved heat transfer. The tubes are used in surface condensers, evaporators, and heat exchangers and are normally made from the following copper or copper alloys:

Copper or Copper Alloy UNS No.	Type of Metal
C10100	Oxygen-free electronic
C10200	Oxygen-free without residual deoxidants
C10300	Oxygen-free, extra low phosphorus
C10800	Oxygen-free, low phosphorus
C12000	DLP Phosphorized, low residual phosphorus
C12200	DHP, Phosphorized, high residual phosphorus
C14200	DPA Phosphorized arsenical
C19200	Phosphorized, 1% iron
C23000	Red Brass
C44300	Admiralty Metal Types B, C, and
C44400	D
C44550	D
C60800	Aluminum Bronze
C68700	Aluminum Brass Type B
C70400	95-5 Copper-Nickel
C70600	90-10 Copper-Nickel
C71000	80-20 Copper-Nickel Type A
C71500	70-30 Copper-Nickel
C72200	Copper-Nickel

NOTE 1—Refer to Practice E 527 for explanation of Unified Numbering System (UNS).

1.2 The following safety hazard caveat pertains only to the test methods described in this specification.

1.2.1 *This standard does not purport to address all of the safety concerns, if any, associated with its use. It is the responsibility of the user of this standard to establish appropriate safety and health practices and determine the applicability of regulatory limitations prior to use.*

NOTE 2—A complete metric companion, B 359M, has been developed; therefore, no metric equivalents are presented.

2. Referenced Documents

2.1 ASTM Standards:

¹ This specification is under the jurisdiction of ASTM Committee B-5 on Copper and Copper Alloys and is the direct responsibility of Subcommittee B05.04 on Pipe and Tube.

Current edition approved Aug. 15, 1995. Published October 1995. Originally published as B 359 – 60. Last previous edition B 359 – 94.

² For ASME Boiler and Pressure Vessel Code applications see related Specification SB-359 in Section II of that Code.

B 153 Test Method for Expansion (Pin Test) of Copper and Copper-Alloy Pipe and Tubing³

B 154 Test Method for Mercurous Nitrate Test for Copper and Copper Alloys³

B 170 Specification for Oxygen-Free Electrolytic Copper—Refinery Shapes³

B 359M Specification for Copper and Copper-Alloy Seamless Condenser and Heat Exchanger Tubes with Integral Fins [Metric]³

E 3 Methods of Preparation of Metallographic Specimens⁴

E 8 Test Methods for Tension Testing of Metallic Materials⁴

E 29 Practice for Using Significant Digits in Test Data to Determine Conformance with Specifications⁵

E 53 Test Methods for Chemical Analysis of Copper⁶

E 62 Test Methods for Chemical Analysis of Copper and Copper Alloys (Photometric Methods)⁶

E 112 Test Methods for Determining Average Grain Size⁴

E 118 Test Methods for Chemical Analysis of Copper-Chromium Alloys⁶

E 243 Practice for Electromagnetic (Eddy-Current) Examination of Copper and Copper-Alloy Tubes⁷

E 255 Practice for Sampling Copper and Copper Alloys for Determination of Chemical Composition⁶

E 478 Test Methods for Chemical Analysis of Copper Alloys⁶

E 527 Practice for Numbering Metals and Alloys (UNS)⁸

3. Terminology

3.1 Definitions:

3.1.1 *flattening*—this term shall be interpreted as that condition which allows a micrometer caliper, set at three times the wall thickness, to pass over the tube freely throughout the flattened part, except at the points where the change in element of flattening takes place.

3.1.2 *lengths*—straight pieces of product.

3.1.2.1 *lengths, specific*—straight lengths that are uniform in length, as specified, and subject to established length tolerances.

³ Annual Book of ASTM Standards, Vol 02.01.

⁴ Annual Book of ASTM Standards, Vol 03.01.

⁵ Annual Book of ASTM Standards, Vol 14.02.

⁶ Annual Book of ASTM Standards, Vol 03.05.

⁷ Annual Book of ASTM Standards, Vol 03.03.

⁸ Annual Book of ASTM Standards, Vol 01.01.

3.1.3 *tube, seamless*—a tube produced with a continuous periphery in all stages of operation.

3.1.3.1 *tube condenser*—see *tube, heat exchanger*.

3.1.3.2 *tube, heat exchanger*—a tube manufactured to special requirements as to dimensional tolerances, finish, and temper for use in condensers and other heat exchangers.

3.1.3.3 *tube, heat exchangers with integral enhanced surface*—a tube having an external or internal surface, or both, modified by a cold forming operation, to produce an enhanced surface for improved heat transfer. The enhancement may take the form of longitudinal or helical fins or ridges, or both, as well as modifications thereto.

3.1.4 *unaided eye*—corrective spectacles necessary to obtain normal vision may be used.

4. Ordering Information

4.1 Purchase orders for tubes described in this specification should include the following, as required, to describe the tubes adequately.

4.1.1 ASTM designation and year of issue,

4.1.2 Alloy,

4.1.3 Temper,

4.1.4 Dimensions: diameter, wall thickness, length and location of unenhanced surfaces and total tube length. Configuration of enhanced surfaces shall be as agreed upon between the manufacturer and the purchaser. (Refer to Figs. 1, 2, and 3).

4.1.5 Whether the product is to be subsequently welded,

4.1.6 Quantity,

4.1.7 Certification, when required,

4.1.8 Mill test report, when required,

4.1.9 When heat identification or traceability is required, and

4.1.10 When tubes are for Boiler and Pressure Vessel code application, which should then be ordered according to ASME SB 359.

5. General Requirements

5.1 Tubes described by this specification shall normally be furnished with unenhanced ends, but may be furnished with enhanced ends or stripped ends from which the O.D. enhancement has been removed by machining.

5.1.1 The enhanced sections of the tube in the as-fabricated temper are in the cold-worked condition produced by the enhancing operation. The unenhanced sections of the

tube shall be in the annealed or light drawn temper, and shall be suitable for rolling-in operations.

6. Materials and Manufacture

6.1 The material shall be of such quality and purity that the finished products shall conform to the requirements prescribed in this specification and shall be cold-worked to the specified size. To comply with this specification, the enhanced and unenhanced material must be homogeneous.

6.2 Due to the discontinuous nature of the processing of castings into wrought products, it is not practical to identify specific casting analysis with a specific quantity of finished material.

6.3 When heat identification is required, the purchaser shall specify the details desired in the purchase order or contract.

7. Chemical Composition

7.1 The tubes shall conform to the chemical requirements specified in Table 1.

7.2 These specification limits do not preclude the presence of other elements. Limits for unnamed elements may be established by agreement between manufacturer or supplier and purchaser.

7.2.1 *Copper Alloy C19200*—Copper may be taken as the difference between the sum of results for all specified elements and 100 %. When all elements specified, including copper, are determined, their sum shall be 99.8 % minimum.

7.2.2 For alloys in which copper is specified as the remainder, copper may be taken as the difference between the sum of the results for all specified elements and 100 % for the particular alloy.

7.2.2.1 When analyzed, copper plus the sum of results for specified elements shall be as shown in the following table.

Copper Alloy UNS No.	Copper Plus Named Elements, % min
C60800	99.5
C70400	99.5
C70600	99.5
C71000	99.5
C71500	99.5
C72200	99.8

7.2.3 For alloys in which zinc is specified as the remainder, either copper or zinc may be taken as the difference between the sum of the results of specified elements analyzed and 100 %.

7.2.3.1 When all specified elements are determined the sum of results plus copper shall be as follows:

Copper Alloy UNS No.	Copper Plus Named Elements, % min
C23000	99.8
C44300, C44400, C44500	99.6
C68700	99.5

8. Temper

8.1 The tube after enhancing shall be supplied, as specified, in the annealed or as-fabricated temper.

8.1.1 The enhanced sections of tubes in the as-fabricated temper are in the cold-worked condition produced by the fabricating operation.

8.1.2 The unenhanced sections of tubes in the as-fabricated temper are in the temper of the tube prior to

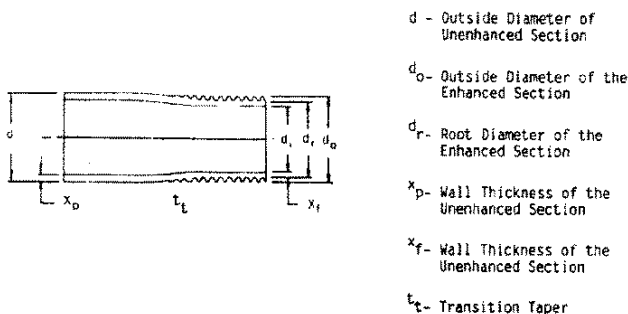

NOTE—The outside diameter over the enhanced section will not normally exceed the outside diameter of the unenhanced section.

FIG. 1 Outside Diameter Enhanced Tube Nomenclature

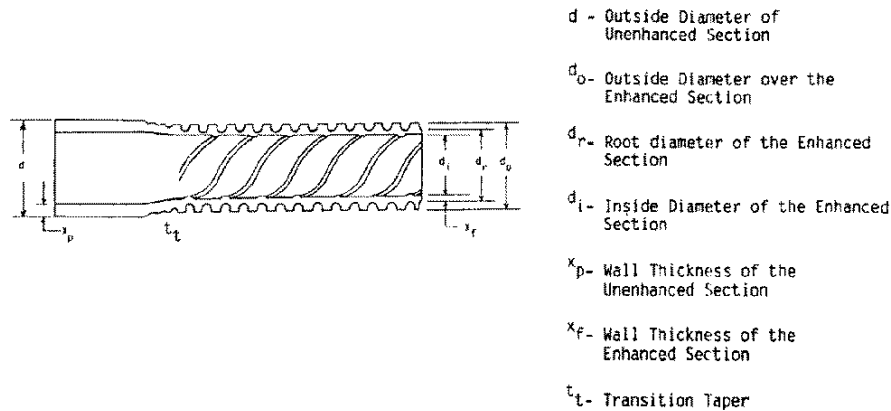

FIG. 2 Outside Diameter and Inside Diameter Enhanced Tube Nomenclature

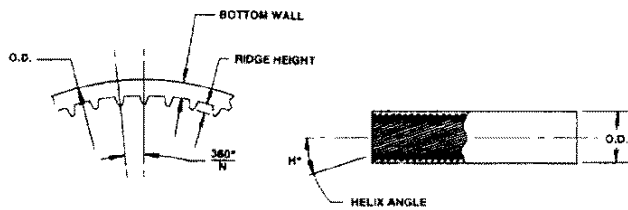

FIG. 3 Inside Diameter Enhanced Tube Nomenclature

enhancing, annealed or light drawn, and suitable for rolling-in operations.

8.1.3 Copper alloys C23000, C44300, C44400, C44500, C60800, and C68700, furnished in the as-fabricated temper, must be stress relief annealed after enhancing and be capable of meeting the requirements of the mercurous nitrate test in section 12. Stress relief annealing of the copper and other copper alloys described by this specification is not required.

8.1.3.1 Some annealed tubes, when subjected to aggressive environments, may be subject to stress-corrosion cracking failure because of the residual tensile stresses developed in straightening. For such applications, it is recommended that tubes of copper alloys C23000, C44300, C44400, C44500, C60800, and C68700 be subjected to a stress relieving thermal treatment subsequent to straightening. When required, this must be specified on the purchase order or contract. Tolerance for roundness and length, and the condition for straightness, for tube so ordered, shall be to the requirements agreed upon between the manufacturer and purchaser.

8.1.4 The enhanced sections of tubes in the annealed temper shall show complete recrystallization when examined in the cross-section of the tube at a magnification of 75 diameters. Average grain size shall be within the limits agreed upon between the manufacturer and purchaser, when measured in the wall of the tube outside of the enhanced area.

9. Tensile Properties

9.1 Prior to the enhancing operation, the tube shall conform to the requirements for tensile properties prescribed in Table 2.

10. Expansion Test

10.1 The unenhanced sections of all tubes selected for test shall conform to the requirements prescribed in Table 3 when tested in accordance with B 153. The expanded tube shall show no cracking or rupture visible to the unaided eye.

11. Flattening Test

11.1 The unenhanced lengths of tube selected for tests shall be flattened on different elements and a flattened element shall show no cracking or rupture visible to the unaided eye. (Corrective spectacles necessary to obtain normal vision may be used.)

12. Mercurous Nitrate Test

12.1 Each specimen shall withstand an immersion in the mercurous nitrate solution as prescribed in Test Method B 154 without cracking. The enhanced specimens shall include the finished tube ends.

12.2 This test is required only for copper alloys C23000, C44300, C44400, C44500, C60800, and C68700.

13. Non-destructive Testing

13.1 Each tube shall be subjected to a non-destructive test. Tubes shall normally be tested in the as-fabricated temper but, at the option of the manufacturer, may be tested in the annealed temper. Unless otherwise specified, the manufacturer shall have the option of testing the tubes by one of the following test methods.

13.1.1 *Eddy-Current Test*—The tubes shall be passed through an eddy-current testing unit adjusted per the requirements of 19.3.3 to provide information on the suitability of the tube for the intended application.

13.1.1.1 Tubes causing irrelevant signals because of moisture, soil, and like effects may be reconditioned and retested. Such tubes shall be considered to conform, should they not cause output signals beyond the acceptable limits.

13.1.1.2 Tubes causing irrelevant signals because of visible and identifiable handling marks may be retested by the hydrostatic test prescribed in 13.1.2 or the pneumatic test prescribed in 13.1.3.

13.1.1.3 Unless otherwise agreed, tubes meeting the requirements of either test shall be considered to conform if the tube dimensions are within the prescribed limits.

TABLE 1 Chemical Requirements

Copper or Copper Alloy UNS No.	Composition, %												
	Copper ^A	Tin	Alumi- num	Nickel, incl Cobalt	Lead, max	Iron	Zinc	Man- ganese	Arsenic	Antimony	Phosphorus	Chromium	Other Named Ele- ments
C10100	99.99 min ^B	0.0002 max	...	0.0010 max	0.0005	0.0010 max	0.0001 max	0.00005 max	0.0005 max	0.0004 max	0.0003 max	...	C...
C10200 ^D	99.95 min
C10300	99.95 min ^E	0.001-0.005
C10800	99.95 min ^E	0.005-0.012
C12000	99.90 min	0.004-0.012
C12200	99.9 min	0.015-0.040
C14200	99.40 min	0.15-0.50	...	0.015-0.040
C19200	98.7 min	0.8-1.2	0.01-0.04
C23000	84.0-86.0	0.05	0.05 max	remainder
C44300	70.0-73.0	0.9-1.2	0.07	0.06 max	remainder	...	0.02-0.06
C44400	70.0-73.0	0.9-1.2	0.07	0.06 max	remainder	0.02-0.10
C44500	70.0-73.0	0.9-1.2	0.07	0.06 max	remainder	0.02-0.10
C60800	remainder	...	5.0-6.5	...	0.10	0.10 max	0.02	0.35
C68700	76.0-79.0	...	1.8-2.5	...	0.07	0.06 max	remainder	...	0.02-0.06
C70400	remainder	4.8-6.2	0.05	1.3-1.7	1.0 max	0.30-0.8
C70600	remainder	9.0-11.0	0.05	1.0-1.8	1.0 max ^F	1.0 max	^F	...	^F
C71000	remainder	19.0-23.0	0.05	0.50-1.0	1.0 max ^F	1.0 max	^F	...	^F
C71500	remainder	29.0-33.0	0.05	0.40-1.0	1.0 max ^F	1.0 max	^F	...	^F
C72200	remainder	15.0-18.0	0.05	0.50-1.0	1.0 max ^F	1.0 max	^F	0.30-0.70	^F

^A Copper (including silver).

^B This value is exclusive of silver and shall be determined by difference of "impurity total" from 100 %. "Impurity total" is defined as the sum of sulfur, silver, lead, tin, bismuth, arsenic, antimony, iron, nickel, mercury, zinc, phosphorus, selenium, tellurium, manganese, cadmium, and oxygen present in the sample.

^C Other impurity maximums for C10100 shall be: bismuth, cadmium and mercury 0.0001 each, oxygen 0.0005, selenium 0.0003, silver 0.0025, sulfur 0.0015, and tellurium 0.0002.

^D Oxygen in C10200 shall be 0.0010 max.

^E Copper plus sum of named elements shall be 99.95 % min.

^F When the product is for subsequent welding applications, and so specified in the contract or purchase order, zinc shall be 0.50 % max, lead 0.02 % max, phosphorus 0.02 % max, and sulfur and carbon 0.05 % max.

TABLE 2 Tensile Requirements

Copper or Copper Alloy UNS No.	Temper Designation		Tensile Strength, min	Yield Strength, ^B min
	Standard	Former	ksi ^A	ksi ^A
C10100, C10200, C10300, C10800, C12000, C12200, C14200	O61	annealed	30	9 ^C
C10100, C10200, C10300, C10800, C12000, C12200, C14200	H55	light-drawn	36	30
C19200	O61	annealed	38	12
C23000	O61	annealed	40	12
C44300, C44400, C44500	O61	annealed	45	15
C60800	O61	annealed	50	19
C68700	O61	annealed	50	18
C70400	O61	annealed	38	12
C70600	O61	annealed	40	15
C71000	O61	annealed	45	16
C71500	O61	annealed	52	18
C72200	O61	annealed	45	16

^A ksi = 1000 psi.

^B At 0.5 % extension under load.

^C Light straightening operation is permitted.

13.1.2 *Hydrostatic Test*—Each tube, without showing evidence of leakage, shall withstand an internal hydrostatic pressure sufficient to subject the material in the unenhanced region of the tube to a fiber stress of 7000 psi, as determined by the following equation for thin hollow cylinders under tension.

$$P = 2St / (D - 0.8t) \quad (1)$$

where:

P = hydrostatic pressure, Psig,

t = thickness of tube wall, in.,

D = outside diameter of tube, in., and

S = allowable fiber stress of the material, psi.

The tube need not be tested at a hydrostatic pressure over 1000 psi unless so specified.

13.1.3 *Pneumatic Test*—Each tube, after enhancing, shall withstand a minimum internal air pressure of 250 psig for 5 s and any evidence of leakage shall be cause for rejection. The test method used shall permit easy visual detection of any leakage, such as having the tube under water, or by the pressure differential method.

13.2 When tubes are specified to meet the requirements of the ASME Boiler and Pressure Vessel Code, a pressure test as described in 13.1.2 or 13.1.3 is required.

TABLE 3 Expansion Requirements

Temper Designation		Copper or Copper Alloy UNS No.	Expansion of Tube Outside Diameter in Percent of Original Outside Diameter
Standard	Former		
O61	annealed	C10100, C10200, C10300, C10800, C12000, C12200, C14200	30
H55	light-drawn	C10100, C10200, C10300, C10800, C12000, C12200, C14200	20
O61	annealed	C19200	30
O61	annealed	C23000	20
O61	annealed	C44300, C44400, C44500	20
O61	annealed	C60800	20
O61	annealed	C68700	20
O61	annealed	C70400	30
O61	annealed	C70600	30
O61	annealed	C71000	30
O61	annealed	C71500	30
O61	annealed	C72200	30

14. Dimensions and Permissible Variations

14.1 *Diameter*—The outside diameter of the unenhanced sections shall not vary by more than the amount shown in Table 4, as measured by “go” and “no go” ring gages. The diameter over the enhanced sections shall not exceed diameter of the plain sections involved, as determined by a “go” ring gage, unless otherwise specified.

14.2 *Wall Thickness*—No tube shall be less than the minimum thickness specified in the plain sections or in the enhanced sections.

14.3 *Length*—The length of the tubes shall not be less than that specified when measured at a temperature of 68°F, but may exceed the specified value by the amounts shown in Table 5.

14.3.1 The length of the unenhanced end(s), as measured from the tube end to the first fin disk impression, shall not be less than that specified, but may exceed the specified value by 1/2 inch.

14.4 *Squareness of Cut*—The departure from squareness of the end of any tube shall not exceed the tolerance stated in Table 6.

15. Workmanship, Finish, and Appearance

15.1 Roundness, straightness, uniformity of wall thickness, and condition of inner and outer surfaces of the tube shall be such as to make it suitable for the intended

TABLE 4 Diameter Tolerances

Specified Diameter, in.	Tolerance, in.
0.500 and under	±0.002
Over 0.500–0.740, incl	±0.0025
Over 0.740–1.000, incl	±0.003

TABLE 5 Length Tolerances

Specified Length, ft	Tolerance, all Plus, in.
Up to 20, incl	1/8
Over 20–30, incl	5/32
Over 30–60, incl	1/4

TABLE 6 Squareness of Cut

Specified Outside Diameter, in.	Tolerance
Up to 1/2, incl	0.010 in.
Over 1/2	0.016 in./in. of diameter

application. Unless otherwise specified on the purchase order, the cut ends of the tubes shall be deburred by use of a rotating wire wheel or other suitable tool.

15.2 Annealed-temper or stress-relieved tubes shall be clean and smooth, but may have a superficial, dull iridescent film on both the inside and outside surface. Tubes in the as-fabricated temper may have a superficial film of finning lubricant on the surfaces.

16. Sampling

16.1 The lot size, portion size, and selection of sample pieces shall be as follows:

16.1.1 *Lot Size*—600 tubes or 10 000 lbs or fraction of either, whichever constitutes the greater weight.

16.1.2 *Portion Size*—Sections from two individual lengths of finished product.

16.1.2.1 Samples taken for purposes of test shall be selected in a manner that will correctly represent the material furnished and avoid needless destruction of finished material when samples representative of the material are available from other sources.

16.2 *Chemical Composition*—Samples for determining composition shall be taken in accordance with Practice E 255. The minimum weight of the composite sample shall be 150 g.

16.2.1 Instead of sampling in accordance with Practice E 255, the manufacturer shall have the option of sampling at the time castings are poured or sampling the semi-finished product. When samples are taken during the course of manufacture, sampling of the finished product is not required and the minimum number of samples to be taken shall be as follows:

16.2.1.1 When samples are taken at the time castings are poured, one sample shall be taken for each group of castings poured simultaneously from the same source of molten metal.

16.2.1.2 When samples are taken from the semi-finished product, one sample shall be taken to represent each 10 000 lbs or fraction thereof, except that not more than one sample shall be required per piece.

17. Number of Tests and Retest

17.1 *Tests:*

17.1.1 Chemical composition shall be determined as the

arithmetic mean of at least two replicate determinations of each specified element.

17.1.2 All other tests specified in sections 8 through 12 shall be conducted on specimens taken from each of the samples selected in accordance with 16.1.

17.2 Retest:

17.2.1 One retest shall be permitted for each requirement under the same conditions stated for the original test.

17.2.2 Should the result of a retest fail to conform with the requirements of the product specification, the material shall be rejected.

18. Specimen Preparation

18.1 Preparation of the analytical test specimen shall be the responsibility of the reporting laboratory.

18.2 Specimens for the microscopic examination shall be prepared in accordance with Methods E 3.

18.2.1 The surface of the specimen shall approximate a radial longitudinal section of the tube.

18.3 Specimens for the expansion test shall be of suitable length so that they can be expanded the required amount. Both ends shall either be faced square in a lathe, or suitably prepared so as to have a smooth surface free from scratches or burrs, and with both edges slightly chamfered.

18.4 Specimens for the flattening test require no special preparation, but shall be of the length necessary to accommodate the test.

18.5 Specimens for the mercurous nitrate test shall be 6 inches in length and shall be taken from the enhanced and unenhanced portion of each sample.

18.6 Tension test specimens shall be of the full section of the tube and shall conform to the requirements of the 'Test Specimen' section of Test Methods E 8, unless the limitations of the testing machine precludes the use of such specimen in which case test specimens conforming to specimen No. 1 of Fig. 13 in Test Methods E 8 shall be used.

18.6.1 Whenever test results are obtained from full-sized and machined specimens and they differ, the results from the full-sized specimen shall prevail for determining conformance to the specification.

18.6.2 Although a considerable range of testing speed is permissible, the range of stressing to the yield strength should not exceed 100 ksi/min. Above the yield strength the movement per minute of the testing machine head under load shall not exceed 0.5 in./in. of the gage length, or distance between grips for a full section specimen.

19. Test Methods

19.1 Chemical Composition:

19.1.1 The methods used for routine determination of specification compliance shall be at the discretion of the reporting laboratory.

19.1.2 In case of disagreement concerning chemical composition of alloy C10100, refer to the Test Method Section of Specification B 170.

19.2 Chemical composition for all other alloys, in case of disagreement, shall be determined as follows:

19.2.1 Test methods for the determination of elements resulting from contractual or purchase order agreements shall be as agreed upon between the manufacturer or supplier and purchaser. (Refer to Table 1, Footnote D).

Element	Range	Test Method
Copper	99.75 to 99.99	E 53, Electrolytic
Copper	70.0 to 99.75	E 478, Electrolytic
Tin	0.9 to 1.2	E 478, Photometric
Aluminum	1.8 to 6.5	E 478
Nickel, inc. Cobalt	4.8 to 33.0	E 478, Gravimetric
Lead	0.05 to 0.10	E 478, Atomic Absorption
Iron	0.04 to 1.8	E 478
Zinc	14.0 to 30.0	E 478, Titrimetric
Zinc	to 1.0	E 478, Atomic Absorption
Manganese	to 1.0	E 62
Arsenic	0.02 to 0.5	E 62
Antimony	0.02 to 0.1	E 62
Phosphorus	0.001 to 0.04	E 62
Chromium	0.30 to 0.70	E 118

19.3 The material shall conform to the physical requirements and mechanical properties enumerated in this specification when tested in accordance with the following methods:

Test	ASTM Designation
Grain Size	E 112
Expansion (pin test)	B 153
Mercurous Nitrate	B 154
Tension	E 8
Eddy-Current Test	E 243

19.3.1 Grain Size—The intercept method shall be used to determine grain size in case of dispute.

19.3.2 Test Method B 154—Warning: this test method involves the use of a mercury compound which is classified as a health hazard in use and disposal.

19.3.3 Eddy-Current—Testing shall follow the procedures of Practice E 243, except that the sensitivity settings of the test equipment shall be adjusted using the hole sizes specified in Table 7 of Specification B 359. The holes for sensitivity adjustment shall be drilled radially through an unenhanced portion of the standard tube or through a length of prime surface tube of the same size, temper, and composition. By mutual agreement between the manufacturer or supplier and purchaser, discontinuities of other contours may be used on the calibration standard.

19.3.3.1 Tubes that do not actuate the signaling device on the eddy current tester shall be considered as conforming to the requirements of this test.

20. Significance of Numerical Limits

20.1 For purposes of determining compliance with the specified limits of the properties listed in the following table, an observed or calculated value shall be rounded as indicated in accordance with the rounding method of Practice E 29.

Property	Rounded Unit for Observed or Calculated Value
Chemical Composition	Nearest unit in the last right hand place of figures
Tensile Strength, Yield Strength	Nearest ksi
Grain Size:	
Up to 0.055 mm, incl.,	Nearest multiple of 0.005 mm to the nearest
Over 0.055 mm	0.010 mm

TABLE 7 Diameter of Drilled Holes

Nominal Diameter Over Enhanced or Unenhanced Section, in.	Diameter of Drilled Holes, in.
1/4-5/8, incl	0.042—No. 58 drill
Over 5/8-1, incl	0.046—No. 56 drill

21. Inspection

21.1 The manufacturer shall inspect and make the necessary tests to verify that the tubes furnished conform to the requirements of this specification.

21.2 Should the purchaser additionally elect to perform his own inspection, the manufacturer shall, without charge, afford the inspector all reasonable facilities to determine that the tubes being furnished conform to the requirements of this specification.

21.2.1 Except for chemical analysis, all tests and inspections shall be made at the place of manufacture prior to shipment, unless otherwise specified, and shall be so conducted as not to interfere with the operation of the facility.

21.3 When automated finishing and inspection equipment is available at a facility, purchaser and manufacturer may, by mutual agreement, accomplish the final inspection simultaneously.

22. Rejection and Rehearing

22.1 Material that fails to conform to the requirements of this specification when inspected or tested by the purchaser, or purchaser's agent, may be rejected.

22.2 Rejection shall be reported to the manufacturer, or supplier, promptly and in writing.

21.3 The manufacturer, or supplier, may make claim for a rehearing when dissatisfied with the test results.

23. Certification

23.1 When specified in the purchase order or contract, a

manufacturer's certificate of compliance shall be furnished to the purchaser stating that samples representing each lot have been tested and inspected in accordance with this specification and the requirements have been met.

23.2 When material is specified to meet the requirement of ASME Boiler and Pressure Vessel Code, certification is mandatory.

24. Mill Test Report

24.1 When specified in the purchase order or contract, the manufacturer or supplier shall furnish to the purchaser a manufacturer's test report showing the results of the required tests.

25. Packaging and Package Marking

25.1 The material shall be separated by alloy, size, and temper. It shall be packaged in such a manner as to ensure acceptance by common carrier for transportation and to afford adequate protection from normal hazards of transportation.

25.2 Each shipping unit shall be legibly marked with the name of supplier, purchase order number, metal or alloy designation, temper, size, total length or piece count, or both.

25.3 The specification number shall be shown when specified.

26. Keywords

26.1 copper; copper alloys; seamless; condenser; heat exchanger; tube; integral fins

SUPPLEMENTARY REQUIREMENTS

The following supplementary requirements shall apply only when specified by the purchaser in the inquiry, contract, or order, for agencies of the U.S. Government.

S1. Referenced Documents

S1.1 The following documents of the issue in effect on date of material purchase form a part of this specification to the extent referenced herein.

S1.1.1 *ASTM Standards*:

D 4727—Specification for Corrugated and Solid Fiberboard Sheet Stock (Container Grade) and Cut Shapes⁹

S1.1.2 *Military Standards*:¹⁰

MIL-STD-271—Nondestructive Testing Requirements for Metals

MIL-STD-2035—Nondestructive Testing Acceptance Criteria

S1.1.3 *Military Specifications*:¹⁰

MIL-C-3993—Copper and Copper Base Alloy Mill Products; Packaging of.

MIL-L-19140—Lumber and Plywood, Fire-Retardant Treated

S2. Standard Government Tube Dimensions

S2.1 *Number of Fins*—Tube shall have 19 +1, -0 fins per inch as averaged over any 12 inch length.

S2.2 *Fin Height*—The fin height shall be 0.050 inch, minimum.

S2.3 *Dimensions*—Table S1 lists standard tube diameters and wall thickness.

S2.4 *Root Diameter Tolerances*—A tolerance of plus 0.007 inch and minus 0.003 inch on the root diameter shall be permitted.

S2.5 *Straightness Tolerance*—The straightness tolerances of Table S2 shall apply to as-finned tube only.

S2.6 The tolerances for outside diameter of the unenhanced ends, specified in Table 5, shall be all negative.

S3. Sampling

S3.1 *Lot Definition*—For sampling purposes, a lot shall consist of lengths of tubes of the same composition, temper, size, heat treated at the same time in the same furnace, offered for delivery at the same time and identifiable by mill records as originating from one or more heats (melts), as necessary, which conform to the chemical requirements. The total weight of the lot shall not exceed 10 000 pounds.

⁹ Annual Book of ASTM Standards, Vol 15.09.

¹⁰ Available from Standardization Documents Order Desk, Bldg. 4 Section D, 700 Robbins Ave., Philadelphia, PA 19111-5094, Attn: NPODS.

TABLE S1. Dimensions of Integral Finned Condenser Tubes (minimum wall)

Nominal		Unenhanced Section		Enhanced Section	
Outside Diameter	Wall	Outside Diameter	Specified Minimum Wall	Root Diameter	Specified Minimum Wall
Inch	Inch	Inch	Inch	Inch	Inch
1/2	0.032	0.500	0.049	0.375	0.032
1/2	0.042	0.500	0.058	0.375	0.042
1/2	0.049	0.500	0.065	0.375	0.049
5/8	0.028	0.625	0.042	0.500	0.028
5/8	0.035	0.625	0.049	0.500	0.035
5/8	0.049	0.625	0.065	0.500	0.049
5/8	0.058	0.625	0.072	0.500	0.058
5/8	0.065	0.625	0.083	0.500	0.065
3/4	0.028	0.750	0.049	0.625	0.028
3/4	0.035	0.750	0.052	0.625	0.035
3/4	0.042	0.750	0.058	0.625	0.042
3/4	0.049	0.750	0.065	0.625	0.049
3/4	0.058	0.750	0.075	0.625	0.058
3/4	0.065	0.750	0.083	0.625	0.065
3/4	0.072	0.750	0.086	0.625	0.072
3/4	0.083	0.750	0.095	0.625	0.083
3/4	0.095	0.750	0.109	0.625	0.095
7/8	0.035	0.875	0.052	0.750	0.035
7/8	0.042	0.875	0.058	0.750	0.042
7/8	0.049	0.875	0.065	0.750	0.049
7/8	0.058	0.875	0.075	0.750	0.058
7/8	0.065	0.875	0.083	0.750	0.065
7/8	0.072	0.875	0.086	0.750	0.072
7/8	0.083	0.875	0.095	0.750	0.083
1	0.042	1.000	0.058	0.875	0.042
1	0.049	1.000	0.065	0.875	0.049
1	0.058	1.000	0.075	0.875	0.058
1	0.065	1.000	0.083	0.875	0.065
1	0.072	1.000	0.086	0.875	0.072
1	0.083	1.000	0.095	0.875	0.083

S3.2 Visual and Dimensional Examination—From each lot, a representative sample of tubes shall be selected in accordance with Table S3 for inspection to the requirements of Section 11 Dimensions and Permissible Variations and Section 12 Workmanship, Finish and Appearance of Specification B 359 and Section 2 of this supplement.

S3.3 Destructive Tests—From each lot a representative sample for flattening, flaring and grain size tests as specified in Specification B 359 shall be selected in accordance with Table S4.

S4. Nondestructive Testing

S4.1 Eddy Current and Pressure Tests—Both eddy current and pressure tests are required.

S4.2 Eddy Current Procedure—An eddy current test shall be performed which meets the requirements specified in Specification B 359 and MIL-STD-271.

S4.2.1 Liquid Penetrant Inspection—Liquid penetrant inspection in accordance with MIL-STD-271 shall be performed on the outside surface and the end surfaces of the smooth ends of the tubes to inspect the area of the tubes missed by the eddy current test due to “end effect.” Alternatively,

the area of the tube ends missed may be cropped off and discarded. Liquid penetrant acceptance criteria shall be in accordance with MIL-STD-2035.

S5. Preparation for Delivery

S5.1 Military Agencies—Material shall be separated by size, and composition and shall be preserved and packaged level A or C, packed level A, B, or C, as specified in the purchase order or contract in accordance with the requirements of MIL-C-3993. In addition when specified in the contract or purchase order the following shall apply:

TABLE S3 Sampling for Visual and Dimensional Examinations

Lot Size	Sample Size
2-13	All
14-150	13
151-280	20
281-500	29
501-1200	34
1201-3200	42

TABLE S4 Sampling for Destructive Tests

Lot Size	Sample Size
1-25	2
26-50	3
51-90	4
91-150	5
151-280	6
281-500	7
501-1200	8
1201-3200	9

TABLE S2 Permissible Variations in Straightness of Tube

Length (feet)	Maximum Curvature (depth of arc) (inch)
Over 3 to 6 inclusive	3/16
Over 6 to 8 inclusive	5/16
Over 8 to 10 inclusive	1/2
Over 10	1/2 Inch in any 10 foot portion of the total length

S5.1.1 *Fire Retardant Requirements:*

S5.1.1.1 *Lumber and Plywood*—All lumber and plywood including laminated veneer materials used in shipping container and pallet construction, members, blocking, bracing, and reinforcing shall be fire retardant treated materials conforming to MIL-L-19140 as follows:

Level A and B	Type II—weather resistant Category I—general use
Level C	Type I—non weather resistant Category I—general use

S5.1.1.2 *Fiberboard*—Fiberboard used in the construction

of boxes including interior packaging forms shall conform to the class-domestic/fire retardant or class-weather resistant/fire retardant materials requirements, as specified in the acquisitioning document, of Specification D 4727.

S5.1.2 Cushioning or wrapping materials shall be provided to prevent damage and to prevent free movement of the container contents. The use of excelsior, newspaper, shredded paper and similar hydroscopic or non-neutral materials and all types of loose fill materials for packaging applications such as cushioning, fill, stuffing and dunnage is prohibited.

The American Society for Testing and Materials takes no position respecting the validity of any patent rights asserted in connection with any item mentioned in this standard. Users of this standard are expressly advised that determination of the validity of any such patent rights, and the risk of infringement of such rights, are entirely their own responsibility.

This standard is subject to revision at any time by the responsible technical committee and must be reviewed every five years and if not revised, either reapproved or withdrawn. Your comments are invited either for revision of this standard or for additional standards and should be addressed to ASTM Headquarters. Your comments will receive careful consideration at a meeting of the responsible technical committee, which you may attend. If you feel that your comments have not received a fair hearing you should make your views known to the ASTM Committee on Standards, 1916 Race St., Philadelphia, PA 19103.